



SSI-273SH

Soft Serve Machine



Features

Two Flavors & One Twist.
Can serve Yogurt & Soft Ice Cream.

Heat Treatment System

Provides a daily heating and cooling cycle to safely maintain dairy products up to 28 days before a complete disassembly and cleaning is required.

Mix Hopper

Two, 9.5 liter (2.61 gallon) capacity.
Maintain the temperature of mix, under 5°C (41°F) in Auto & Stand by mode.

Freezing Cylinder

One, 2.7 liter (0.72 gallon) capacity.

Load Control System

Check the electronic current every seconds from the dasher motor to produce high quality of soft serve.

Convenience Functions



Agitator



Touch Screen



Water Supply



Drainage Hole



ISO 9001:2007
REGISTERED



P: 0845 302 4592

F: 0845 302 4593

E: sales@smoothieoperators.co.uk

W: www.smoothieoperators.co.uk

Drawings

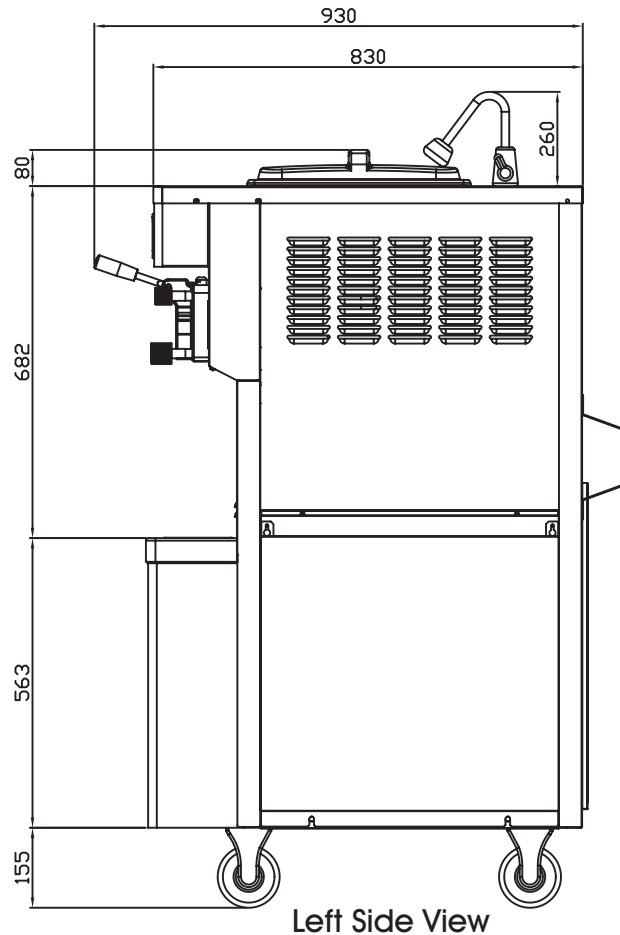
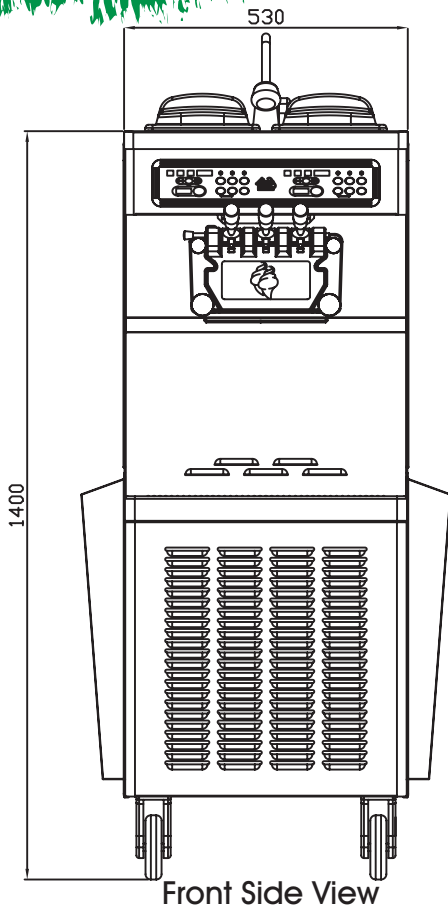

Exterior

Dimensions	Net .		Gross .	
	mm	inch	mm	inch
Width	530	20.9	630	24.8
Depth	930	36.6	1030	40.6
Height	1660	65.3	1860	73.2

Weight	Net .		Gross .	
	kgs	lbs	kgs	lbs
	270	595	285	628

Volume - 1.2 cu. m

Electrical

Power consumption	4,500 Watt(3PH)
Vol tage	208~230V/60Hz/1PH
	380~440V/50~60Hz/3PH

Specifications

Refrigeration System

Comp	No.	Brand	Watt	BTU	Ref .
Freezing	2ea	Aspera	1782	6083	R404A
Cooling	-	-	-	-	-

*Air-Cooling condenser.

*BTUs may vary depending on compressor used.

Production Capacity

Max. Production	42Kg/h (92.6bs/h)
First Dispensing	7~11min
Consecutive Dispensing	16~40cups(100cc/3.5oz)
Dispensing per hour	420cups(100cc/3.5oz)

*Production Capacity may vary depending on ambient temperature.

Dasher Motor

Two, 0.65Kw (0.88Hp)

*Product's exterior and specifications can be modified without prior notice.



P: 0845 302 4592

F: 0845 302 4593

E: sales@smoothieoperators.co.uk

W: www.smoothieoperators.co.uk