



SSI-203S

Soft Serve Machine



Features

- Two Flavors & One Twist.
- Can serve Yogurt & Soft Ice Cream.

Mix Hopper

- Two, 10liter (2.64gallon) capacity.
- Maintain the temperaturer of mix, under 5°C (41°F) in Auto & Stand by mode.

Freezing Cylinder

- One, 2.7liter (0.72gallon) capacity.

Touch Screen Display

- Adjust all the settings from the touch panel.
- Voice guide function available.



Load Control System

- Check the electronic current every seconds from the dasher motor to produce high quality of soft serve.

Standby Mode

- During long no-use time, Standby mode keep the Mix Hopper and Freezing Cylinder cooling.



ISO 9001:2007
REGISTERED



P: 0845 302 4592

F: 0845 302 4593

E: sales@smoothieoperators.co.uk

W: www.smoothieoperators.co.uk

Drawings

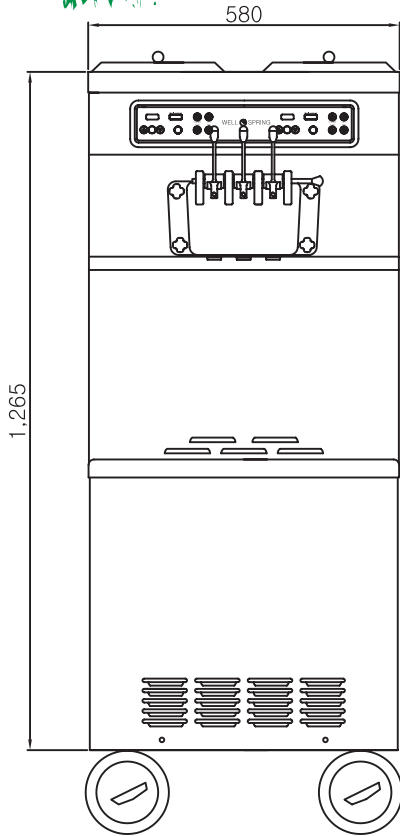

Front Side View

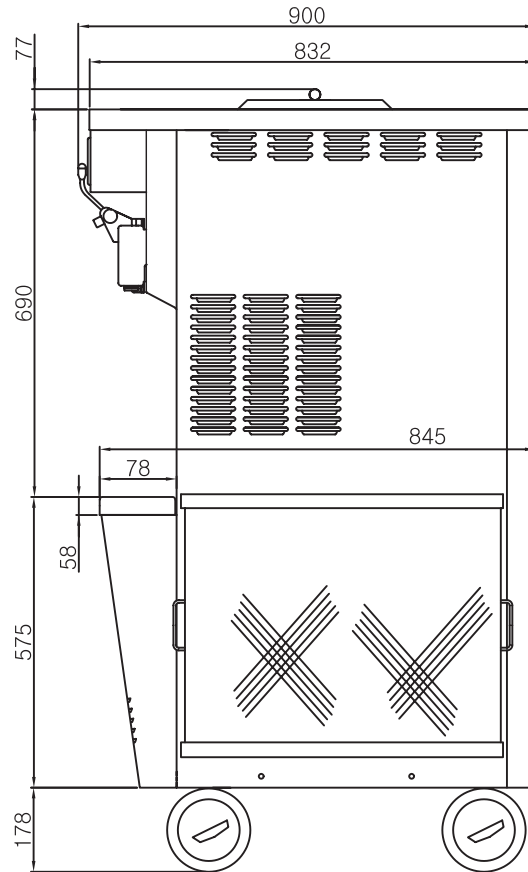

Left Side View

Exterior

Dimensions	Net .		Gross .	
	mm	inch	mm	inch
Width	580	22.9	710	28.0
Depth	900	35.5	1020	40.2
Height	1520	59.9	1660	65.4

Weight	Net .		Gross .	
	kgs	lbs	kgs	lbs
	250	552	265	584
Volume	-		1.3 cu. m	

Electrical

Power consumption	4,500 Watt
Voltage	208~230V/60Hz/1PH
	229~240V/50Hz/1PH

Specifications

Refrigeration System

Comp	No.	Brand	Watt	BTU	Ref .
Freezing	2ea	Aspera	1545	5272	R404A
Cooling	1ea	ACC	199	679	R134A

*Air-Cooling condenser.

*BTUs may vary depending on compressor used.

Production Capacity

Max. Production	42Kg/h (92.6bs/h)
First Dispensing	7~11min
Consecutive Dispensing	16~40cups (100cc/3.5oz)
Dispensing per hour	420cups (100cc/3.5oz)

*Production Capacity may vary depending on ambient temperature.

Dasher Motor

Two, 0.75Kw (1.0Hp)

*Product's exterior and specifications can be modified without prior notice.



P: 0845 302 4592

F: 0845 302 4593

E: sales@smoothieoperators.co.uk

W: www.smoothieoperators.co.uk