



SSI-151TG

Soft Serve Machine



Features

- Single Falvor.
- Can serve Yogurt & Soft Ice Cream.

Mix Hopper

- One, 10liter (2.64gallon) capacity.
- Maintain the temperatuer of mix, under 5 °C (41 °F) in Auto & Stand by mode.

Freezing Cylinder

- One, 1.4liter (0.37gallon) capacity.

Touch Screen Display

- Adjust all the settings from the touch panel.
- Voice guide function available.



Load Control System

- Check the electronic current every seconds from the dasher motor to produce high quality of soft serve.

Standby Mode

- During long no-use time, Standby mode keep the Mix Hopper and Freezing Cylinder cooling.



ISO 9001:2007
REGISTERED



P: 0845 302 4592

F: 0845 302 4593

E: sales@smoothieoperators.co.uk

W: www.smoothieoperators.co.uk

Drawings

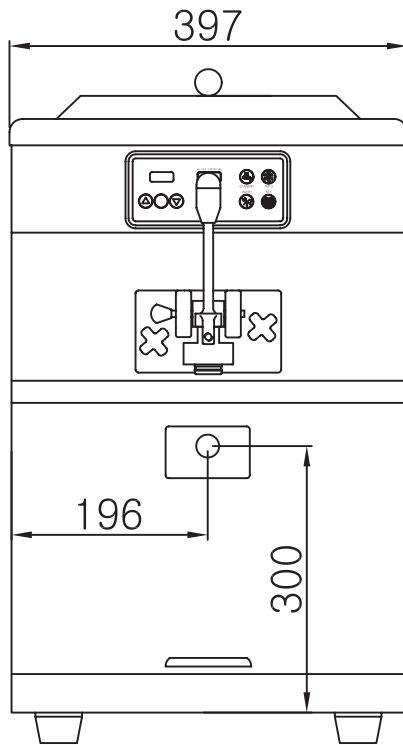

Front Side View

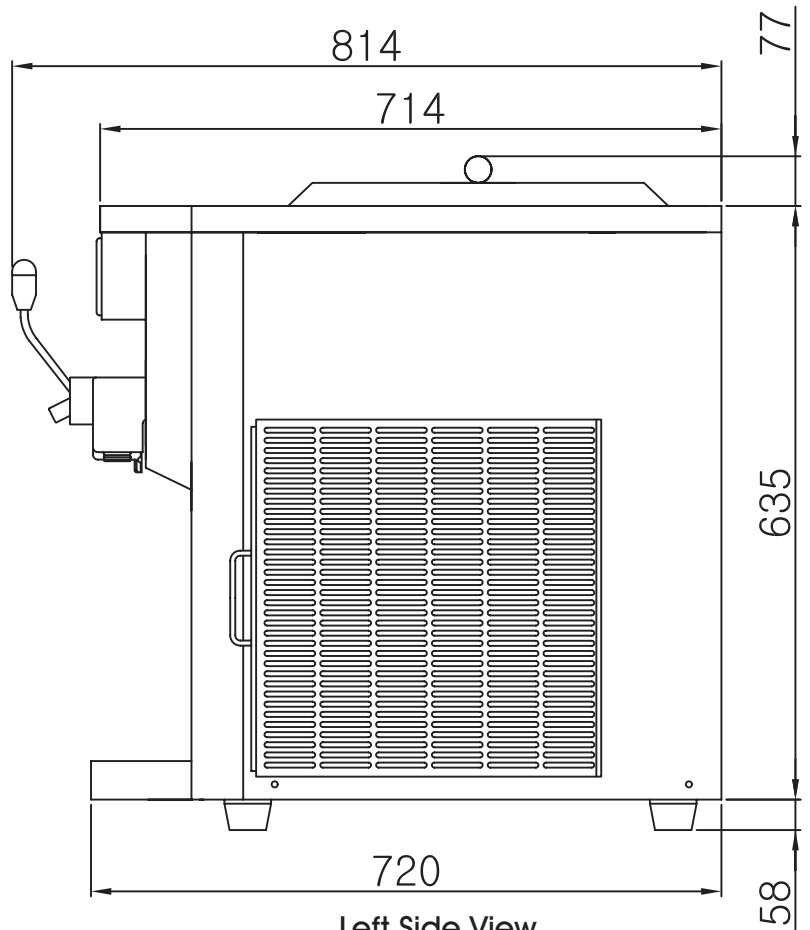

Left Side View

Exterior

Dimensions	Net .		Gross .	
	mm	inch	mm	inch
Width	397	15.7	560	22.1
Depth	814	32.1	880	34.7
Height	771	30.4	870	34.3

Weight	Net .		Gross .	
	kgs	lbs	kgs	lbs
	90	199	100	220

Volume - 0.5 cu. m

Electrical

Power consumption	1,400 W _{att}
Voltage	115V/60Hz/1PH
	208~230V/60Hz/1PH
	229~240V/50Hz/1PH

Specifications

Refrigeration System

Comp	No.	Brand	W _{att}	BTU	Ref .
Freezing	1ea	Aspera	912	3112	R404A
Cooling	1ea	Samsung	150	500	R134A

*Air-Cooling condenser.

*BTUs may vary depending on compressor used.

Production Capacity

Max. Production	16Kg/h (35.3bs/h)
First Dispensing	6~8min
Consecutive Dispensing	5~6cups(100cc/3.5oz)
Dispensing per hour	160cups(100cc/3.5oz)

*Production Capacity may vary depending on ambient temperature.

Dasher Motor

One, 0.37Kw (0.5Hp)

*Product's exterior and specifications can be modified without prior notice.



P: 0845 302 4592

F: 0845 302 4593

E: sales@smoothieoperators.co.uk

W: www.smoothieoperators.co.uk